

DOOSAN INFRACORE INDUSTRIAL ENGINE

SU224TA



Type	emission	Rated RPM	Ratings (kW/PS)	
			Gross Engine Output	Net Engine Output
-	n/a	2600	40.3/54.8	38.8/52.8

◎ GENERAL ENGINE DATA

▶ Engine Model	SU224TA
▶ Engine Type	4-Cycle, In-line, Diesel, Water cooled, T/C
▶ Bore x stroke	Ø87 x 92.4 mm
▶ Displacement	2.197 liters
▶ Compression ratio	21.1 : 1
▶ Rotation	Counter clockwise viewed from Flywheel
▶ Firing order	1-3-4-2
▶ Injection timing	12° BTDC
▶ Dry weight	206kg (with Fan)
▶ Dimension (L x W x H)	773 x 530 x 651 mm
▶ Flywheel housing	SAE No.4
▶ Flywheel	Clutch No.7-1/2
▶ Number of teeth on flywheel	89

◎ EXHAUST SYSTEM

▶ Max. Back Pressure	14.7kPa
----------------------	---------

◎ COOLING SYSTEM

Water circulation by centrifugal pump on engine.	
▶ Cooling method	Fresh water forced circulation
▶ Coolant capacity (Engine Only)	3.8 liters
▶ Coolant flow rate	liters / min
▶ Pressure Cap	90kPa
▶ Water Temperature	
- . Maximum for standby and Prime	110°C
- . Before start of full load	40°C
▶ Water pump	Centrifugal type driven by belt
▶ Thermostat Type and Range	Wax – pellet type□ Opening temp. 71°C , Full open temp. 85°C
▶ Cooling fan	Suction type, Plyproplene , Dia : Ø400mm , 7 blade
▶ Max. external coolant system restriction	Not Available

This is normally attained after a running period of about 100 hours and Image shown may not be actual engine.



◎ LUBRICATION SYSTEM

Force-feed lubrication by gear pump	
▶ Lub. Method	Fully forced pressure feed type
▶ Oil pump	Gear type driven by crank-shaft gear
▶ Oil filter	Full flow, cartridge type
▶ Oil capacity	Max. 9.7 liters
▶ Lub oil pressure	Idle Speed : Min 70 kPa Governed Speed : Min 245kPa
▶ Maximum oil temperature	121°C
▶ Angularity limit	Front down 30 deg , Front up 30 deg□ Side to side 30 deg
▶ Lubrication oil	SAE 10W-30 or SAE 15W-40(Above -10°C)

◎ FUEL SYSTEM

Bosch type in-line pump	
▶ Injection pump	K-type mini pump
▶ Governor	Mechanical centrifugal
▶ Feed pump	Diaphragm type pump
▶ Injection nozzle	Throttle type
▶ Opening pressure	14.7 ~ 15.7Mpa
▶ Fuel filter	Full flow, cartridge type
▶ Fuel feed pump capacity	24 liters / hr
▶ Used fuel	Diesel fuel oil

◎ ELECTRICAL SYSTEM

▶ Battery Charging Alternator	12V x 75A alternator
▶ Voltage regulator	Built-in type IC regulator
▶ Starting motor	12V x 1.7 kW
▶ Battery Voltage	12V
▶ Battery Capacity	80AH(recommended)
▶ Starting aid (Option)	Glow plug

◎ VALVE SYSTEM

▶ Type	Overhead valve type	
▶ Number of valve	Intake 1, exhaust 1 per cylinder	
▶ Valve lashes at cold	Intake 0.20mm , Exhaust 0.20mm	
▶ Valve timing	Open	Close
- . Intake valve	8 deg. BTDC	34 deg. ABDC
- . Exhaust valve	55 deg. BBDC	11 deg. ATDC

This is normally attained after a running period of about 100 hours and Image shown may not be actual engine.



◎ **PERFORMANCE DATA**

SU224TA

▶ Governed Engine speed	rpm	2600
▶ Engine Idle Speed	rpm	1000
▶ Over speed limit	rpm	2800
▶ Gross Eng. Power	kW	40.3
	PS	54.8
▶ BMEP	Mpa	8.63
▶ Mean Piston Speed	m/s	8.01
▶ Specific fuel consumption	L/hr	12.8

The all data and the specific fuel consumption are based on ISO 3046/1, Standard reference conditions are in accordance with 298 K(25° Celsius) air temperature, 100kPa(1000mbar) air pressure, 30% relative humidity, 100m(328ft) altitude. Engine output is affected by atmospheric pressure, temperature and humidity. Therefore, an engine should be selected with sufficient power to meet the load demands under all operating conditions. Provided output be corrected for various atmospheric conditions by above standards, For detail information, refer to deration coefficient table.

◎ **Engine Data with Dry Type Exhaust Manifold**

▶ Intake Air Flow	m ³ /min	2.56
▶ Exh. gas temp. after turbo.	°C	550
▶ Exhaust Gas Flow	m ³ /min	2.70

This is normally attained after a running period of about 100 hours and Image shown may not be actual engine.

◎ **ENGINE DIMENSION**

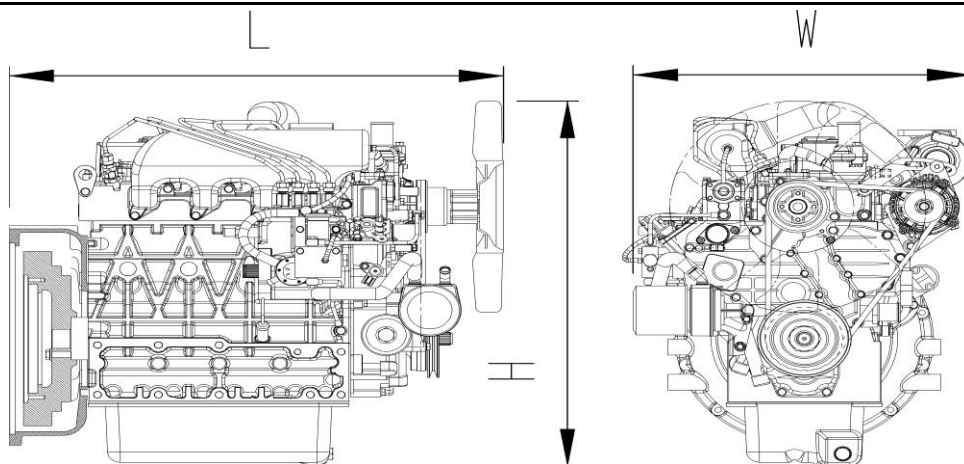

Designation	Length(L)	Width(W)	Height(H)	Dry weight
Value	773mm	530mm	651mm	206kg

◎ **CONVERSION TABLE**

in. = mm x 0.0394	lb/ft = N.m x 0.737
PS = kW x 1.3596	U.S. gal = lit. x 0.264
psi = kg/cm ² x 14.2233	kW = 0.2388 kcal/s
in ³ = lit. x 61.02	lb/PS.h = g/kW.h x 0.00162
hp = PS x 0.98635	cfm = m ³ /min x 35.336
lb = kg x 2.20462	Mpa = Pa x 1000 = bar x 10
kW = Kcal/sec x 0.239	

This is normally attained after a running period of about 100 hours and Image shown may not be actual engine.

