

## DOOSAN INFRACORE INDUSTRIAL ENGINE

# SU183NA

Type	emission	Rated RPM	Ratings (kWm/PS)	
			Gross Engine Output	Net Engine Output
-	n/a	2600	28.3/38.5	26.8/36.4



### ◎ GENERAL ENGINE DATA

▶ Engine Model	SU183NA
▶ Engine Type	3-Cycle, In-line, Diesel, Water cooled, N/A
▶ Bore x stroke	Ø87 x 102.4 mm
▶ Displacement	1.826 liters
▶ Compression ratio	22 : 1
▶ Rotation	Counter clockwise viewed from Flywheel
▶ Firing order	1-2-3
▶ Injection timing	18° BTDC
▶ Dry weight	180kg (with Fan)
▶ Dimension (L x W x H)	672 x 510 x 700 mm
▶ Flywheel housing	SAE No.4
▶ Flywheel	Clutch No.7-1/2
▶ Number of teeth on flywheel	89

### ◎ EXHAUST SYSTEM

▶ Max. Back Pressure	9.8kPa
▶ Cooling method	Fresh water forced circulation
▶ Coolant capacity (Engine Only)	3.0 liters
▶ Coolant flow rate	liters / min
▶ Pressure Cap	90kPa
▶ Water Temperature	
- . Maximum for standby and Prime	110°C
- . Before start of full load	40°C
▶ Water pump	Centrifugal type driven by belt
▶ Thermostat Type and Range	Wax – pellet type □ Opening temp. 71°C , Full open temp. 85°C
▶ Cooling fan	Suction type, Plyproplene , Dia : Ø400mm , 8 blade
▶ Max. external coolant system restriction	Not Available

This is normally attained after a running period of about 100 hours and Image shown may not be actual engine.



## ◎ LUBRICATION SYSTEM

Force-feed lubrication by gear pump	
▶ Lub. Method	Fully forced pressure feed type
▶ Oil pump	Gear type driven by crank-shaft gear
▶ Oil filter	Full flow, cartridge type
▶ Oil capacity	Max. 5.8 liters
▶ Lub oil pressure	Idle Speed : Min 70 kPa Governed Speed : Min 245kPa
▶ Maximum oil temperature	121°C
▶ Angularity limit	Front down 30 deg , Front up 30 deg Side to side 30 deg
▶ Lubrication oil	SAE 10W-30 or SAE 15W-40(Above -10°C)

## ◎ FUEL SYSTEM

Bosch type in-line pump	
▶ Injection pump	K-type mini pump
▶ Governor	Mechanical centrifugal
▶ Feed pump	Diaphragm type pump
▶ Injection nozzle	Throttle type
▶ Opening pressure	14.7 ~ 15.7Mpa
▶ Fuel filter	Full flow, cartridge type
▶ Fuel feed pump capacity	24 liters / hr
▶ Used fuel	Diesel fuel oil
▶ Voltage regulator	Built-in type IC regulator
▶ Starting motor	12V x 1.7 kW
▶ Battery Voltage	12V
▶ Battery Capacity	80AH(recommended)
▶ Starting aid (Option)	Glow plug

## ◎ VALVE SYSTEM

▶ Type	Overhead valve type	
▶ Number of valve	Intake 1, exhaust 1 per cylinder	
▶ Valve lashes at cold	Intake 0.25mm , Exhaust 0.30mm	
▶ Valve timing	Open	Close
- . Intake valve	8 deg. BTDC	38 deg. ABDC
- . Exhaust valve	42 deg. BBDC	8 deg. ATDC

This is normally attained after a running period of about 100 hours and Image shown may not be actual engine.



◎ **PERFORMANCE DATA**

**SU183NA**

▶ Governed Engine speed	rpm	2600
▶ Engine Idle Speed	rpm	1000
▶ Over speed limit	rpm	2800
▶ Gross Eng. Power(Stand by)	kWm	28.3
efficiency	90%	
	kWe	25.5
	kVA	31.8
	PS	38.5
▶ BMEP	Mpa	7.3
▶ Mean Piston Speed	m/s	8.9
▶ Specific fuel consumption	L/hr	8.9

The all data and the specific fuel consumption are based on ISO 3046/1, Standard reference conditions are in accordance with 298 K(25° Celsius) air temperature, 100kPa(1000mbar) air pressure, 60% relative humidity, 110m(361ft) altitude.

Operation At Elevated Temperature And Altitude: The engine may be operated at :

1800 rpm & 1500rpm up to 750~ 1000m and 30°C without power deration

For sustained operation above these conditions, derate by 3% per 304m , and 2% per 11 °C

◎ **Engine Data with Dry Type Exhaust Manifold**

▶ Intake Air Flow	m³/min	1.81
▶ Exh. gas temp. after turbo.	°C	590
▶ Exhaust Gas Flow	m³/min	1.92

◎ **ENGINE DIMENSION**

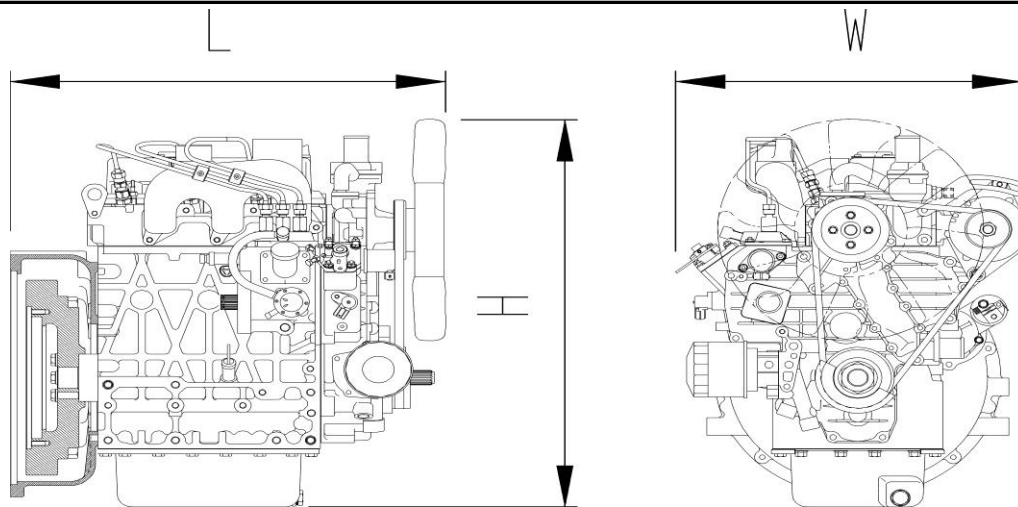

Designation	Length(L)	Width(W)	Height(H)	Dry weight
Value	672mm	510mm	700mm	180kg

◎ **CONVERSION TABLE**

in. = mm x 0.0394

PS = kW x 1.3596

psi = kg/cm<sup>2</sup> x 14.2233

in<sup>3</sup> = lit. x 61.02

hp = PS x 0.98635

lb = kg x 2.20462

kW = Kcal/sec x 0.239

lb/ft = N.m x 0.737

U.S. gal = lit. x 0.264

kW = 0.2388 kcal/s

lb/PS.h = g/kW.h x 0.00162

cfm = m<sup>3</sup> /min x 35.336

Mpa = Pa x 1000 = bar x 10

This is normally attained after a running period of about 100 hours and Image shown may not be actual engine.

