

DOOSAN INFRACORE GENSETS ENGINES

SP404TA



Ratings (kWm)	Gross Engine Output		Net Engine Output	
	Standby	Prime	Standby	Prime
1500rpm(50Hz)	73	66	71	64
1800rpm(60Hz)	83	76	80	73

Ratings Definitions

Electric power(kWe) should be estimated by considering generator efficiency, cooling fan power loss and power derating due to altitude and ambient temperature.

STANDBY POWER RATING is applicable for supplying emergency power for the duration of the utility power outage.

No overload capability is available for this rating. A standby rated engine should be sized for a maximum of an 70% average load factor and 200 hours of operation per year. This includes less than 25 hours per year at the Standby Power rating.

PRIME POWER RATING is available for an unlimited of hours per year in variable load application. Variable load should not exceed a 70% average of the Prime Power rating during any operating period of 24 hours. The Total operating time at 100% Prime Power shall not exceed 500 hours per year. A 10% overload capability is available for a period of 1 hour within a 12 hour period of operation. Total operating time at the 10% overload power shall not exceed 25 hours per year.

◎ GENERAL ENGINE DATA

○ Engine Model	SP404TA
○ Engine Type	4-Cycle, In line,vertical,water cooled,four-stroke,dry liner,direct injection
○ Bore x stroke	100×127 mm
○ Displacement	3.99 liters
○ Compression ratio	17.5: 1
○ Rotation	Clockwise viewed from the front
○ Firing order	1-3-4-2
○ Dry weight	522 kg(with Fan)
○ Dimension (LxWxH)	1253×706×946mm
○ Idle speed	700±30 rpm
○ Governor Regulation	≤5%
○ Maximum permissible high altitude	3000 m
○ Instantaneous maximum value	3381 N
○ Continuous maximum value	2135 N
○ Moment of inertia	0.1254 kgm ²

◎ AIR INTAKE SYSTEM

○ The maximum temperature rise	15 °C
○ Maximum inlet temperature	52 °C
○ Minimum inlet pressure	100 KPa
○ Maximum permissible air intake restriction at engine (d 5 kPa	
○ Maximum permissible air intake restriction at engine (c 3 kPa	
○ Air filter type	Dry element type
○ Minimum dirt capacity	353 g/m ³ /min

◎ EXHAUST SYSTEM

○ Maximum permissibleback pressure for total system	6 KPa
○ Exhaust gas flow(prime)	13.1 (50HZ) ,14 (60HZ) m ³ /min
○ Exhaust gas flow(standby)	15.9 (50HZ) ,17 (60HZ) m ³ /min
○ Exhaust gas temperature(prime)	561 (50HZ) ,511 (60HZ) °C
○ Exhaust gas temperature(standby)	596 (50HZ) ,548 (60HZ) °C

◎ COOLING SYSTEM

○ Total system coolant capacity	25.5 L
○ Thermostat operation range	82-88 °C
○ Maximum permissible external system resistance	35 kPa
○ Maximum temperature to engine	100 °C
○ Minimum temperature to engine	70 °C
○ Coolant temperature alarm	101 °C
○ Limits of the environment temperature	45 °C
○ Maximum static pressure head at pump	6.2m/1500rpm,4.3m/1800rpm

◎ RADIATOR SYSTEM

○ Radiator	pipe and belt
○ Radiator pipe area	26.94 m ²
○ Length x width x height	628X221X830 mm
○ Pressure cap setting	75 kPa
○ Maximum top tank temperature	103 °C

◎ FAN SYSTEM

○ Diameter	510 mm
○ Driver ratio	1.25
○ Num	9
○ Material	plastic

◎ LUBRICATION SYSTEM

○ Lubrication oil capacity (sump)	6.9 L
○ Lubrication oil capacity (total)	8.5 L
○ Lubrication oil pressure	310-390 kPa
○ Lubrication oil temperature	At normal operation 105°C , Maximum 125°C
○ Lubrication oil consumption as a percentage of fuel con	0.2% maximum
○ Pressure at which oil relief valve opens	345-414 kPa

◎ FUEL SYSTEM

○ Pump	Injection pump
○ Fuel lift pump pressure	1.8 kg
○ Maximum pressure head	95 MPa

◎ ELECTRICAL SYSTEM

○ Alternator	12/24 V
○ Starter motor	12/24 V

◎ ENGINE DIMENSION

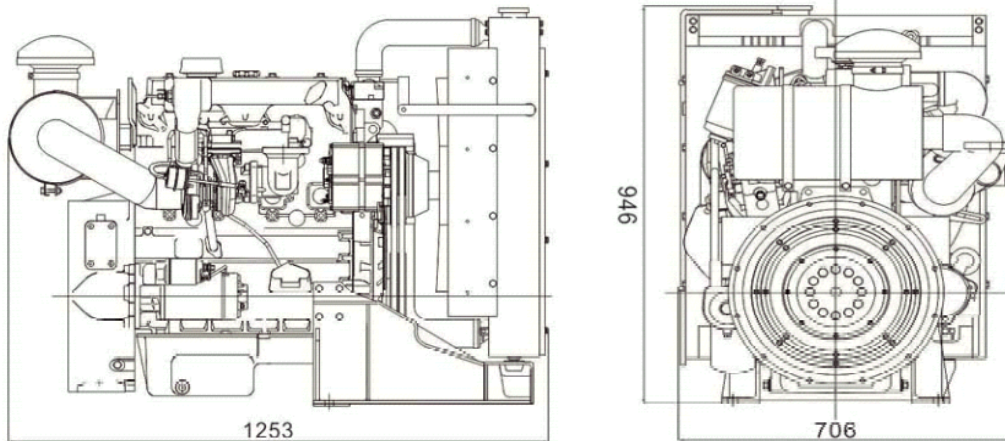

◆ CONVERSION TABLE

in. = mm x 0.0394	lb/ft = N.m x 0.737
PS = kW x 1.3596	U.S. gal = lit. x 0.264
psi = kg/cm ² x 14.2233	kW = 0.2388 kcal/s
in ³ = lit. x 61.02	lb/PS.h = g/kW.h x 0.00162
hp = PS x 0.98635	cfm = m ³ /min x 35.336
lb = kg x 2.20462	MPa = kPa x 1000 = bar x 10
kW = kcal/sec x 0.239	

Doosan Infracore Co., Ltd
28st Floor, Doosan Tower, 18-12, Euljiro 6-ga, Jung-gu, Seoul, Korea.

TEL : +82-2-3398-8899/ FAX : +82-2-3398-8898
E-mail : enginesales@doosan.com
Web site : www.doosaninfracore.com