

Intermittent rating kW(HP) / rpm	Max. torque N.m(kg.m) / rpm	After-treatment
100.7(135.1) / 2600	500(51.0) / 1400	DOC+SDPF+SCR  (No EGR)
85.8(115.0) / 2600	445(45.4) / 1600	
77.9(105.0) / 2600	407(41.5) / 1600	
71.6(96.0) / 2600	372(37.9) / 1600	

**CERTIFIED  
STAGE V**



### ◆ General Engine Data

• Engine Type	In-line, 4-cycle
• Number of Cylinders	4
• Displacement	3,409 liter
• Bore x Stroke	98 x 113 mm
• Compression Ratio	18.0 : 1
• Firing Order	1 - 3 - 4 - 2
• Aspiration	Turbocharged and air-to-air aftercooled
• Combustion System	Direct injection
• Rotation	Counter clockwise viewed from Flywheel
• Clutch	SAE#3 - 11/5" / SAE#4 - 10" (SAE J620)
• Dry weight	464 kg (with after-treatment) 564 kg (with powerpack)
• Front PTO	100% Engine torque available at 2300 rpm
• Side PTO (1st / 2nd)	Continuous 110Nm / 200Nm (SAE A)
• Valve System Type	Over head valve
• Number of Valves	Intake 2, exhaust 2 per cylinder Hydraulic Valve Lash Adjust

### ◆ Electrical System

• Alternator	12V x 110A / 12V x 140A / 24V 80A
• Voltage Regulator	Built-in type IC regulator
• Starting Motor	12V x 2.5kW / 24V x 5.0kW
• Battery Voltage	12V /24V
• Battery Capacity	100 Ah, 750CCA (recommended)
• Starting Aid	Glow plug

### ◆ Fuel System

• Injection pump	Bosch Common-rail Pump
• Governor	Controlled by ECU
• Fuel filter	Full flow, cartridge type
• Used fuel	Ultra-Low Sulfur Diesel fuel only
• Diesel consumption (g/kWh)	222 @2,600 rpm, 202 @1,400 rpm (135HP) 224 @2,600 rpm, 208 @1,600 rpm (115HP) 226 @2,600 rpm, 206 @1,600 rpm (105HP) 228 @2,600 rpm, 204 @1,600 rpm (96HP)
• DEF Consumption	7~8% of Diesel consumption

### ◆ Engineering Data

• Water flow	140 liters/min @2,600 rpm (135HP)
• Heat Rejection	
- to coolant	15.3 kcal/sec @2,600 rpm (135HP)
- to coolant	13.4 kcal/sec @2,600 rpm (115HP)
- to coolant	12.7 kcal/sec @2,600 rpm (105HP)
- to CAC	4.0 kcal/sec @2,600 rpm (135HP)
- to CAC	3.1 kcal/sec @2,600 rpm (115HP)
- to CAC	1.4 kcal/sec @2,600 rpm (105HP)
• Air flow	7,680 liter/min @2,600 rpm (135HP)
• Exhaust gas temp	750 °C ↓ @2,600 rpm
• Maximum Permission Restrictions	
- Intake system	3.0 kPa clean filter 6.5 kPa dirty filter
- Exhaust system	50 kPa max.

(Please see an Installation Guide for the detail information.)

### ◆ Cooling System

• Cooling method	Fresh water forced circulation
• Water capacity	4.7 liter (engine only) 13.1 liter (with powerpack)
• Water pump	Centrifugal type driven by belt
• Cooling fan	Suction/Blower type, Ø460 (optional)
• Water temperature	110°C (max.)

### ◆ Lubrication System

• Oil filter	Full flow, cartridge type
• Oil pan capacity	High level 12.6 liters (up to 115HP) Low level 6.0 liters (up to 115HP) High level 14.3 liters (135HP) Low level 6.4 liters (135HP)
• Angularity limit	35 deg all around
• Lubrication oil	10W30/40 (API CK-4 / ACEA E6)
• Maximum oil temp	135°C at main oil gallery
• Lub oil pressure	Idle Speed : Min 100 kPa

**100.7kW (135.1HP) @2600**

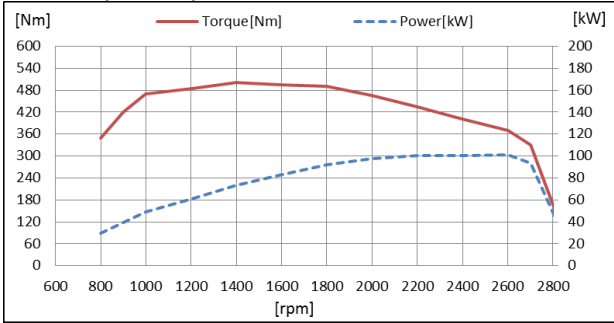

speed	Power			Torque	
	kW	PS	HP	Nm	kgm
800	29.3	39.9	39.3	350	35.7
1000	49.2	66.9	66.0	470	47.9
1200	60.9	82.9	81.7	485	49.5
1400	73.3	99.7	98.3	500	51.0
1600	82.9	112.8	111.2	495	50.5
1800	92.4	125.6	123.9	490	50.0
2000	97.4	132.4	130.6	465	47.4
2200	100.2	136.3	134.4	435	44.4
2400	100.5	136.7	134.8	400	40.8
2600	100.7	137.0	135.1	370	37.7
2700	93.3	126.9	125.1	330	33.7

**85.8kW (115.0HP) @2600**

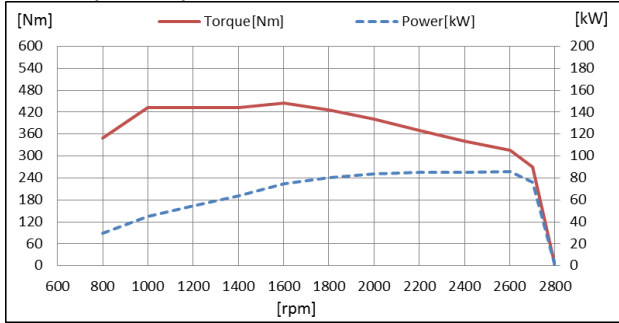

speed	Power			Torque	
	kW	PS	HP	Nm	kgm
800	29.3	39.9	39.3	350.0	35.7
1000	45.2	61.5	60.7	432.0	44.1
1200	54.3	73.8	72.8	432.0	44.1
1400	63.3	86.1	84.9	432.0	44.1
1600	74.6	101.4	100.0	445.0	45.4
1800	80.3	109.2	107.7	426.0	43.4
2000	84.0	114.2	112.6	401.0	40.9
2200	85.2	115.9	114.3	370.0	37.7
2400	85.5	116.2	114.6	340.0	34.7
2600	85.8	116.6	115.0	315.0	32.1
2700	76.3	103.8	102.4	270.0	27.5

**77.9kW (105.0HP) @2600**

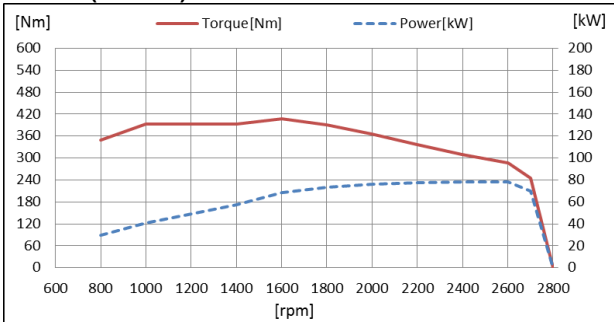

speed	Power			Torque	
	kW	PS	HP	Nm	kgm
800	29.3	39.9	39.3	350.0	35.7
1000	41.1	55.8	55.0	392.0	40.0
1200	49.3	67.0	66.1	392.0	40.0
1400	57.5	78.1	77.1	392.0	40.0
1600	68.2	92.7	91.4	407.0	41.5
1800	73.5	99.9	98.6	390.0	39.8
2000	76.4	103.9	102.5	365.0	37.2
2200	77.6	105.6	104.1	337.0	34.4
2400	77.9	105.9	104.5	310.0	31.6
2600	78.3	106.4	105.0	287.5	29.3
2700	69.6	94.6	93.3	246.0	25.1

**71.6kW (96.0HP) @2600**

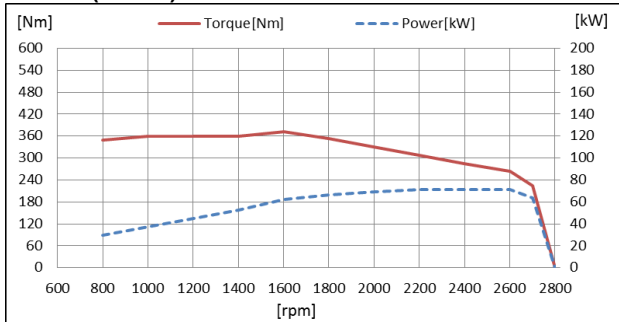

speed	Power			Torque	
	kW	PS	HP	Nm	kgm
800	29.3	39.9	39.3	350.0	35.7
1000	37.6	51.1	50.4	359.0	36.6
1200	45.1	61.3	60.5	359.0	36.6
1400	52.6	71.6	70.6	359.0	36.6
1600	62.3	84.7	83.6	372.0	37.9
1800	66.7	90.7	89.5	354.0	36.1
2000	69.3	94.3	93.0	331.0	33.8
2200	71.0	96.5	95.2	308.0	31.4
2400	71.4	97.0	95.7	284.0	29.0
2600	71.6	97.4	96.0	263.0	26.8
2700	63.6	86.5	85.3	225.0	22.9

## ◆ Engine Dimension

- Dimension (L×W×H) 938 × 686 × 1,129 mm (up to 115HP)

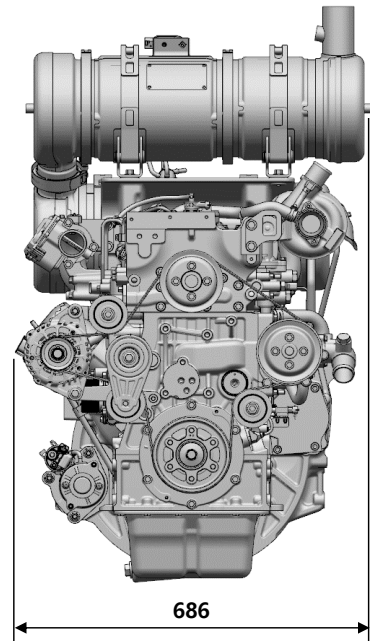
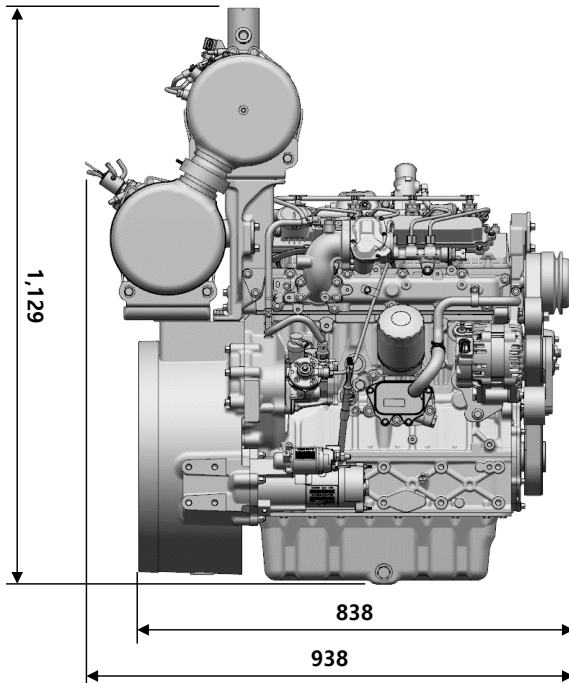

- Dimension (L×W×H) 938 × 711 × 1,140 mm (135HP)

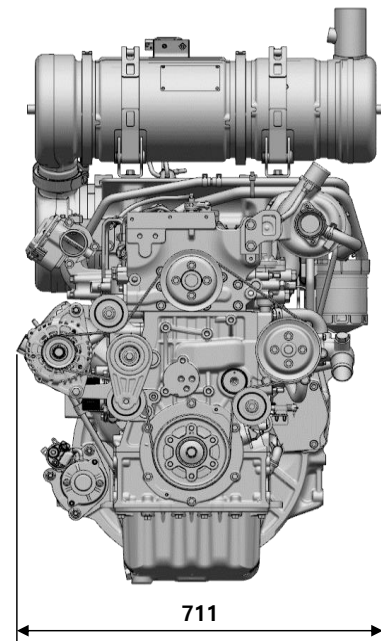
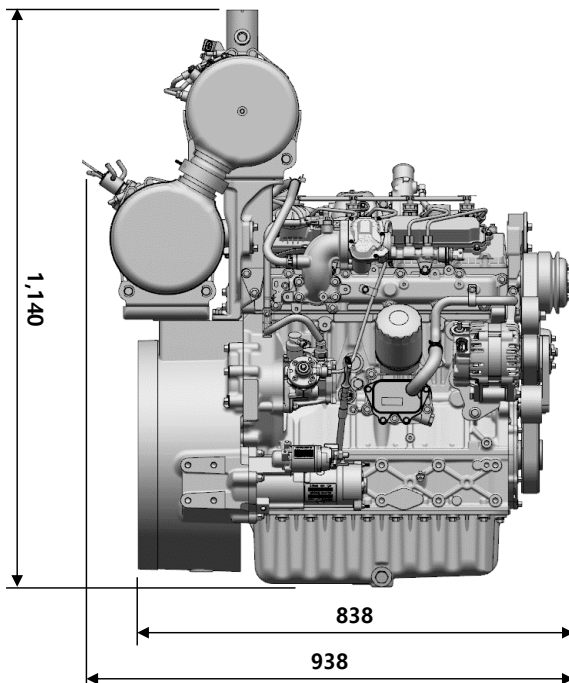

## ◆ Conversion Table

in. = mm x 0.0394	hp = PS x 0.98635	kW = 0.2388 kcal/s
PS = kW x 1.3596	lb = kg x 2.20462	lb/PS.h = g/kW.h x 0.00162
psi = kg/cm <sup>2</sup> x 14.2233	lb/ft = N.m x 0.737	cfm = m <sup>3</sup> /min x 35.336
in <sup>3</sup> = lit. x 61.02	U.S. gal = lit. x 0.264	

### Doosan Infracore Co., Ltd.

28th Floor, Doosan Tower, 275, Jangchungdan-ro, Jung-gu, Seoul, Republic of Korea (04563)

Tel : +82 2 3398 8893 / Fax : +82 2 3398 8898

E-mail : enginesales@doosan.com

Website : www.doosaninfracore.com

※Specifications are subject to change without prior notice.

Powered by  
**Innovation**